

THE EFFECTS OF LEAKAGES IN ROOFS WITH VENTILATED AIR LAYERS - A CFD APPROACH

Zbynek Svoboda

Department of Building Structures, Czech Technical University,
Thakurova 7, 166 29 Prague, Czech Republic, e-mail: svobodaz@fsv.cvut.cz

ABSTRACT

The following paper is focused on hygrothermal behaviour of roofs with ventilated air layers subjected to air leakages in their internal decks (the internal partial construction located below the ventilated air layer). Possibilities of CFD modelling of such constructions are discussed in the first part of the paper including the problem of introduction of water vapour diffusion into calculation. A brief comparison of results from CFD analysis and from calculation based on a technical standard is also included. The main part of the paper includes a case study concerning various effects of leakages in three basic types of ventilated roofs. General conclusion discussing the significance of leakages is included in the final part of the paper.

KEYWORDS

CFD analysis, ventilated roofs, leakages, heat and moisture transfer, condensation risk

INTRODUCTION

Roofs with air layers ventilated by external air used to be recommended frequently as optimal roof constructions for buildings with moist internal microclimate in the past decades. Their incidence nowadays is not so large but they are still being built – and often still in the cases of swimming pools and similar buildings with complicated operation.

The hygrothermal behaviour of these constructions is strongly dependent on the tightness of the internal partial construction separating the ventilated air layer from interior. If this “internal deck” is sufficiently impermeable, the water vapour transport to the ventilated air layer is reduced and the air ventilation ensures that any remaining water vapour transferred into the construction is safely ventilated away without condensation. On the other hand, any leakage or crack in this part of the roof construction can lead to serious damages caused by the condensation on the upper cold deck (during the winter period with low external temperatures).

Calculation procedures for the assessment of ventilated roof constructions, which can be found in some technical standards (e.g. CSI 2005) generally do not consider the effects of local leakages and cracks. These simple calculation models are based on

air pressure, heat and moisture balance equations in the air channel with transverse heat and water vapour flows. The solution is typically derived with the assumption that all the flows have two-dimensional characteristic only (Figure 1) and that these transport processes can be separated one from another and solved sequentially – starting from the solution of air pressure balance equation and ending with the solution of moisture balance equation. Theory for these simple models can be found for example in Hagendoft (2001).

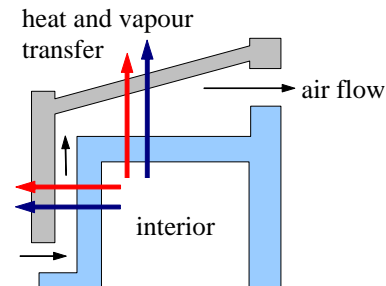

Figure 1 Simple model of a ventilated layer

The effects of leakages were not actually so important in the past when the thermal resistances of the internal decks were usually considerably lower than they are nowadays. The air layers were due to that fact warmer and the condensation risk in the cold winter days was not so high. Contemporary ventilated roofs with high thermal resistances are in much more condensation risk and should be preferably evaluated by means of more advanced calculation procedures such as computational fluid dynamics (CFD) modelling – especially in the cases of spatially complicated roofs.

The objective of this paper is to present the possibilities of this calculation technique for the modelling of hygrothermal behaviour of ventilated roof constructions - including the effects of various leakages in their internal decks. However, the use of CFD approach for this purpose brings also some problems, which should be discussed first.

WATER VAPOUR DIFFUSION IN CFD

The possibilities of CFD modelling are generally very extensive. On the other hand, the time necessary for the calculation can be quite long and sometimes even unacceptable for the common design practice.

In the case of sloping roof constructions, the desirable simplification of the calculation model (which leads to faster calculation) is hardly reachable because all the sloping layers must be modelled – and that results in high number of unknown values.

Nevertheless, far more important problem is the fact that CFD programs generally do not calculate the water vapour diffusion through the building constructions (or in more general terms: through materials). The modelling of water vapour condensation and evaporation is usually also limited to some basic cases (e.g. condensation or evaporation over the surface of a planar region with known, constant surface humidity). Interstitial water vapour condensation in building constructions is also typically excluded from CFD calculations.

These drawbacks can be bypassed in various ways – usually depending on the software being used. Various researchers already dealt with the most important problem – the modelling of water vapour diffusion – and presented some interesting solutions. One of the most motivating was the idea of replacing the materials being exposed to water vapour diffusion by “immobile fluids” with known water vapour diffusion coefficients (Mortensen et al. 2005). Unfortunately, such idea is not applicable to all CFD programs. The other possibility, which is more generally usable, is to model the water vapour flow rate through the internal deck by means of a planar source of moisture. This source should be placed on the external surface of the internal deck and its capacity should be calculated, which is not so simple because the water vapour flow rate depends also on the unknown values of air temperature and humidity in the ventilated air layer. Not all CFD programs offer satisfying procedures how to handle this problem. For example, there is a possibility to enter the moisture source as a linear source in the commonly used CFD program Flovent 6.1 (FLOMERICS 2005) but the built-in equation for this type of source is too simple:

$$g_d = \beta \cdot (x_s - x_a) \quad (1).$$

Equation (1) assumes that the temperature and relative humidity on the surface of the moisture source is constant, which means that the user can enter the water vapour content of air x_s as known input value. This is sufficiently correct in cases when the moisture source is connected to a large mass with high thermal inertia (e.g. water pool). The case of the ventilated roof is different because temperature and relative humidity vary over the surface of the roof's internal deck, and therefore the water vapour flow rate (or the capacity of the moisture source) should be calculated from general equation

$$g_d = \frac{p_i - p_a}{Z_{pl}} \quad (2),$$

which can be also expressed using the water vapour contents of air as

$$g_d = \frac{R_{H_2O}}{Z_{pl}} (x_i T_i \rho_i - x_a T_a \rho_a) \quad (3).$$

Subscripts i and a stand for the internal air and for the air in the ventilated air layer respectively. Comparing equations (1) and (3), one can see that the temperature dependence is missing in equation (1) (dependence on the air density can be neglected in common tasks due to its minor influence). Fortunately, this difficulty is not fundamental in many cases. If one accepts results with a certain safety margin, it is possible to calculate the water vapour flow rate from equation (2) with the initial assumption that the air in the ventilated air layer has the properties of the external air. Such assumption leads to higher resulting water vapour content of air in the ventilated air layer, which is quite acceptable if the results are used mainly to check the quality of the roof design.

Results that are more exact can be obtained by means of iteration with the water vapour flow rate calculated in one step after another using the results (temperature and relative humidity of the air in the ventilated layer) from previous steps. The convergence of this process is quite rapid even for the roofs with low diffusion resistance of the internal deck situated above moist internal environment. Figure 2 shows results of iteration for a simple ventilated roof with U-value of the internal deck 0.13 W/(m²K) and low equivalent diffusion thickness s_d of 4.5 m (Figure 3). The following boundary conditions were considered: air volume flow of 0,019 m³/s in the ventilated air layer, outdoor air temperature -15 °C and relative humidity 84 %, indoor air temperature 20 °C and relative humidity 90 %. All results were obtained by means of 3D calculation using LVEL k-ε turbulence model with total number of 261 000 grid cells.

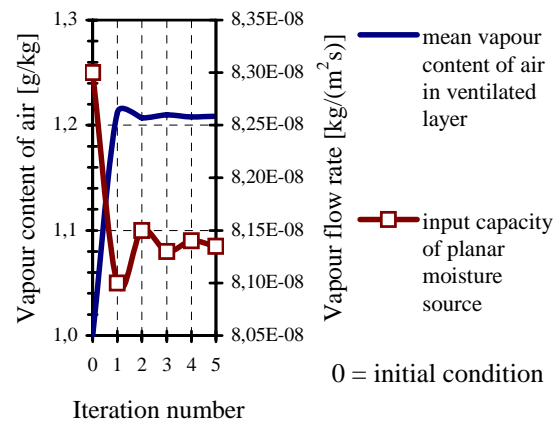

Figure 2 Iteration results for the test case

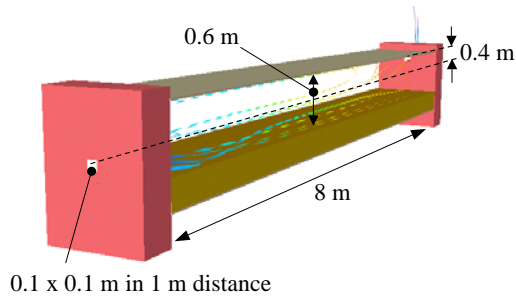

Figure 3 Simple ventilated flat roof

The last thing to mention is that equation (2) is valid only when no condensation occurs in the internal deck - but this condition can be usually satisfied with no major problems.

STANDARD AND CFD ANALYSES

Interesting issue is a comparison between the results of CFD analysis and the results of commonly used simple procedures from technical standards. This comparison is highly important mainly for building design practitioners who are usually familiar only with the standard methods accepting them as a verified tool for the evaluation of ventilated roofs.

The correspondences and differences between both approaches can be clearly shown on the basic type of ventilated roof (Figure 4). The hygrothermal behaviour of this roof depends mainly on thermal and diffusion resistances of its internal deck, on vertical distance between openings and on the wind velocity.

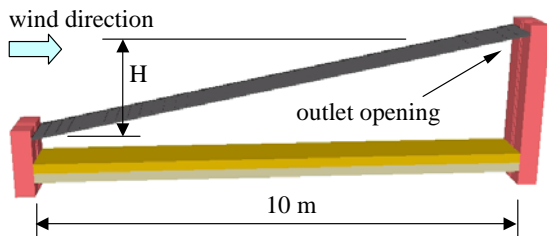

Figure 4 Basic type of a ventilated roof

In the parametric study, both geometry of the ventilated air layer and the size of openings (0.1 x 0.1 m in the distance of 1 m) were considered the same for all test cases. Boundary conditions were also identical (internal air: 21 °C and 50 %, external air: -15 °C and 84 %). Thermal transmittance of the internal deck was variable as well as the vertical distance between openings. Both openings were taken as completely open and resistance-free in order to avoid the differences due to different modelling of air flow resistances.

The temperature and relative humidity of air in the centre of outlet were studied. The first compared method was CFD analysis (FLOMERICS 2005)

using 3D LEVEL k-ε turbulence model with total number of 278 000 grid cells. The second analysed method was standard simple calculation based on CSI 2005. The results are summarised in Table 1. It is apparent that in most cases the standard procedure gives less positive, more “secure” results with higher relative humidity of air (note especially the cases with calm external air). On the other hand, the results of the standard method are more optimistic for higher wind velocities (2 m/s and above). The best agreement between both compared methods can be found for the wind velocity around 1 m/s. It is worth a note that very similar results can be obtained also for other basic types of ventilated roofs (Svoboda 2006).

The differences in results are caused by the fact that the standard procedure does not take into account the air flow in the ventilated layer in all its complexity, including for example the heat conduction through walls (Figure 5).

The spatial distribution of water vapour content of air is also worth a brief mention. Figure 6 shows that the humidity field in the ventilated air layer is dependent on the wind velocity in the same way as the temperature field (Figure 5). However, the scale on Figure 6 indicates that the differences among various values of water vapour content of air in the ventilated layer are almost negligible. Besides, the water vapour content of air in all parts of the ventilated layer is

Table 1 Results of comparative calculation (CFD versus standard procedure)

VERTICAL DISTANCE (INLET/OUTLET)	U-VALUE OF THE INTERNAL DECK	WIND VELOCITY	TEMPERATURE OF AIR AT THE OUTLET		RELATIVE HUMIDITY OF AIR AT THE OUTLET	
			θ [°C]		ϕ [%]	
			CFD	CSI	CFD	CSI
1.0	0.4	0.0	-6.6	-10.1	48	51
		1.0	-10.5	-10.4	58	58
		2.0	-11.8	-11.1	65	61
	0.2	0.0	-9.5	-12.2	64	73
		1.0	-11.9	-12.4	67	70
		2.0	-13.1	-12.8	72	71
	0.1	0.0	-11.1	-13.5	71	85
		1.0	-13.1	-13.6	74	78
		2.0	-13.8	-13.8	76	78
2.0	0.4	0.0	-8.3	-10.2	53	58
		1.0	-10.9	-10.5	60	60
		2.0	-12.2	-11.1	67	61
	0.2	0.0	-10.3	-12.2	63	71
		1.0	-12.3	-12.4	69	70
		2.0	-13.2	-12.8	73	71
	0.1	0.0	-11.5	-13.5	69	81
		1.0	-13.4	-13.6	76	78

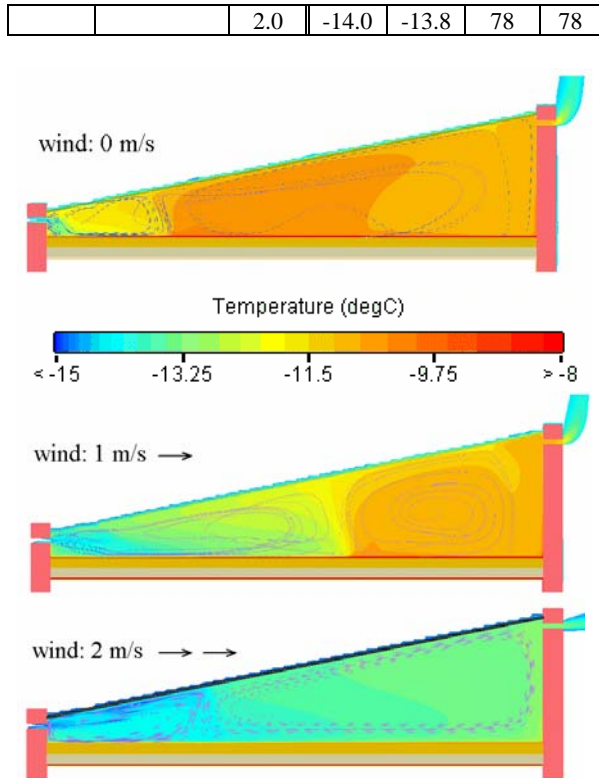

Figure 5 Temperature field and air flow paths in the ventilated layer of the roof with vertical distance between openings $H=2$ m and U -value of the internal deck 0.2 $W/(m^2 \cdot K)$

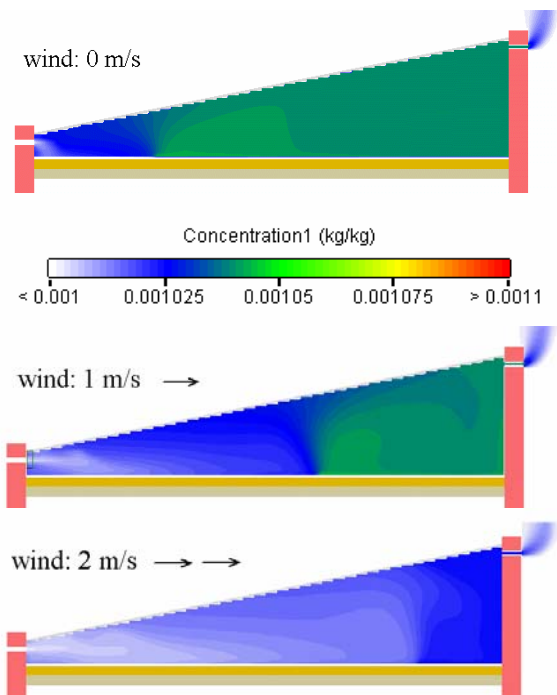

Figure 6 Field of water vapour content of air in the ventilated layer of the same roof as on Figure 5

only slightly above 1 g/kg which is the value corresponding to the water vapour content of the external air. This fact is one of the signs of a proper

design of the chosen model roof.

The water vapour content of air in the ventilated layer would be significantly higher in the case of insufficiently ventilated air layer and/or permeable internal deck. Leakages in roofs are particularly important and deserve a deeper investigation.

EFFECTS OF LEAKAGES

Leakages with their influence on the overall hygrothermal behaviour of building constructions are subject of many recent studies (Wahlgren 2002, Serkitjis et al. 2002, Ge and Fazio 2004, Ciucasu et al. 2005, Svoboda 2006). Most of these studies deal with the thermal effects of leakages but that does not mean that the influence of leakages on the moisture distribution is less essential. On the contrary, because the air flow is able to transport high amounts of water vapour through the construction and this can subsequently induce interstitial condensation with very high condensation rates in the periods with low external temperature. This can even lead to serious damage of such permeable and/or leaky construction.

In the case of flat roofs with ventilated air layers, leakages usually cause heavy local condensation on the internal side of the upper deck (part of the roof with waterproof membrane situated above the ventilated air layer). The condensate can even freeze to this surface creating ice coatings, sometimes with local “stalactites”. These ice layers often melt away quite quickly during warmer days and this usually means that all the water drops down in droplets to the thermal insulation and occasionally even through it to the internal surface of the roof. If the external temperature is higher (slightly above 0 °C) the condensate is not transformed to ice but falls down in droplets right away if its amount is sufficient. Such effects have been recognised as the cause of failures of many roofs.

SIMULATION: A CASE STUDY

Numerical analysis of hygrothermal effects of the leakages in ventilated roofs must be based on a complex model taking into account three-dimensional heat, air and moisture transfer. CFD modelling is a suitable tool for this purpose (although it has still some drawbacks like already discussed modelling of water vapour diffusion). The following case study shows the influence of various leakages on the hygrothermal behaviour of three basic types of ventilated flat roofs (Figure 7). All results were calculated by means of CFD software Flovent 6.1 (FLOMERICS 2005) for the following boundary and other conditions and model settings:

- external air temperature -15 °C and relative humidity 84 %;
- internal air temperature 28 °C and relative humidity 70 % (e.g. swimming pool);

- surface thermal resistances 0,04 m²K/W (external surface) and 0,10 m²K/W (internal surface);

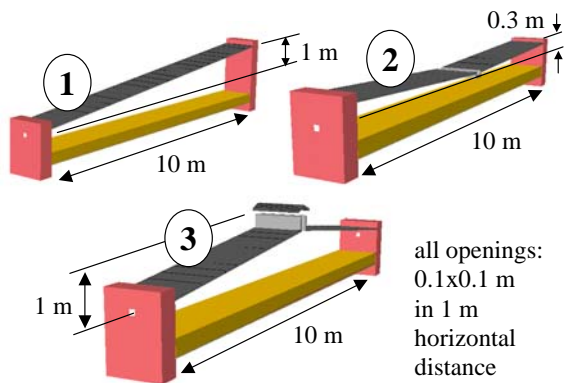

Figure 7 Three types of analysed roofs

- internal (lower) deck with thermal transmittance $U = 0.13 \text{ W}/(\text{m}^2\text{K})$ and equivalent diffusion thickness $s_d = 85 \text{ m}$;
- external (upper) deck with thermal transmittance $U = 4.10 \text{ W}/(\text{m}^2\text{K})$ and equivalent diffusion thickness $s_d = 250 \text{ m}$;
- area of openings to the ventilated air layer $2 \times 0.01 \text{ m}^2$ (inlet and outlet) in the distance of 1 m;
- ventilated air layer with no partitions;
- 3D calculation with LVEL k- ϵ turbulence model;
- calculation models with total number of grid cells from 280 000 up to 850 000 (typical calculation times ranged from 50 to 220 minutes).

The boundary conditions described above were applied to all calculation models according to Figure 8. The capacity of planar moisture source was derived from equation (2) as $5.7 \cdot 10^{-9} \text{ kg}/(\text{m}^2 \cdot \text{s})$.

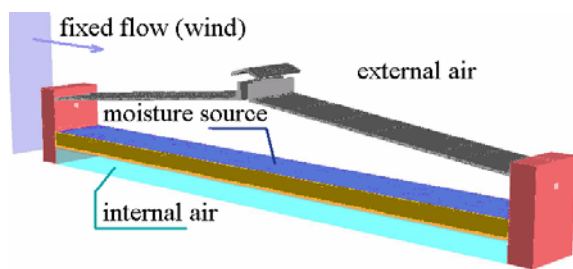

Figure 8 Location of boundary conditions

The mean values of air temperature and water vapour content of air in the ventilated air layer were registered during all calculations as well as the air temperature and water vapour content of air in the centre of the internal face of outlet.

Relative humidity of the air was derived subsequently from these values. Such simple approach is usable without inaccuracies for the cases with relative humidity lower than 100 %. However, it was also necessary to proceed in the same way in the

cases with the air saturated by water vapour. When this happens in the real ventilated roof, the water vapour condensates on most surfaces located in the ventilated air layer. Due to this condensation, the water vapour content of air is never higher than the value corresponding to the relative humidity of 100 % for the given temperature. Unfortunately, such complex process is still impossible to simulate in most CFD software packages. Typical result from a CFD analysis is a spatial field of water vapour content of air calculated without the effects of condensation. Therefore, the final values of water vapour content can be higher than it is possible (they can indicate higher relative humidity than 100 %). Nevertheless, if the purpose of the calculation is just verification of design correctness, such “minor” inaccuracies can be neglected as far as the exact calculated value of water vapour content is not the main issue.

The following states of operation were analysed:

- completely impermeable internal deck;
- internal deck with small leakages regularly distributed over its area;
- internal deck with one single leakage located either near inlet or centre or outlet.

Table 2 Results of the case study

CASE	MEAN VALUES IN THE VENTILATED AIR LAYER			VALUES IN THE CENTRE OF THE OUTLET		
	θ_{am} [°C]	x_{am} [g/kg]	ϕ_{am} [%]	θ_a [°C]	x_a [g/kg]	ϕ_a [%]
Roof 1 : no wind effect						
A	-10.50	1.004	58.6	-9.53	1.005	54.3
B	-10.42	1.034	59.9	-9.48	1.042	56.1
C	-10.16	1.344	76.3	-9.46	1.351	72.6
D	-10.15	1.455	82.5	-9.23	1.473	77.7
E	-10.36	1.382	79.7	-9.04	1.567	81.4
Roof 2 : no wind effect						
A	-9.77	1.012	55.7	-7.73	1.014	47.6
B	-9.69	1.081	59.1	-7.61	1.104	51.3
C	-7.95	3.097	100	-7.17	3.691	100
D	-7.70	3.154	100	-6.80	3.721	100
E	-8.96	2.271	100	-5.00	3.904	100
Roof 3 : no wind effect						
A	-11.92	1.002	65.5	-11.49	1.002	63.2
B	-11.84	1.066	69.2	-11.41	1.071	67.2
C	-10.88	1.755	100	-10.73	1.796	100
D	-10.79	1.762	100	-10.65	1.853	100
E	-11.52	1.313	83.0	-9.08	2.243	100

- Key:** A = impermeable internal deck
 B = regularly distributed small leakages
 C = one leakage located either 2 m from inlet (roofs 1 and 2) or 1 m from inlet (roof 3)
 D = one leakage located between inlet and outlet

E = one leakage located either 1 m from outlet (roofs 1 and 2) or under it (roof 3).

The area of leakages was taken as 0.005 % from the total area of the internal deck in all cases. This percentage had been chosen as realistic low value in order to simulate the leakage area usually observed on existing roofs. All leakages were modelled as holes with planar flow resistances corresponding to 70 % of open space. The rule of minimum number of 4 grid cells in the horizontal section through the holes was applied to all models.

Results of the case study for the assumption of calm external air are presented in Table 2. Temperature fields and distributions of water vapour content of air for the model roof no. 3 can be seen on Figures 9 and 10. Interesting issue is the wind effect, which can be explored in Table 3 and on Figures 11 and 12. The area of the upper deck threatened by the surface condensation is also worth attention (Figure 13).

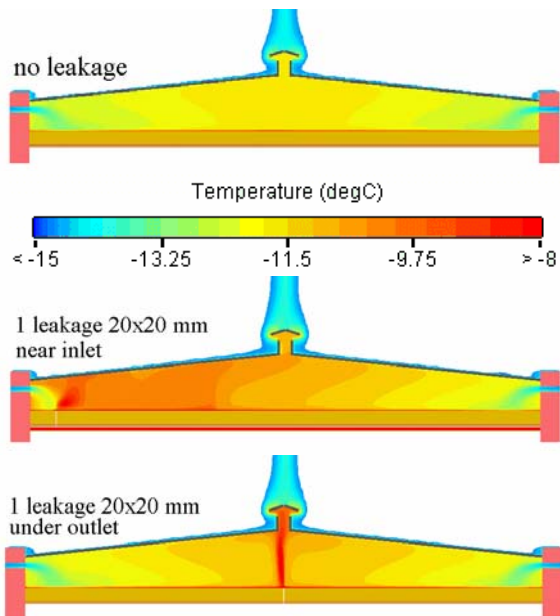

Figure 9 Temperature field in the ventilated layer of the model roof no. 3

ANALYSIS OF RESULTS

Several conclusions can be derived from the results:

- any leakage in the internal deck of the ventilated roof leads to higher temperature and relative humidity of air in the roof's ventilated layer;
- high number of very small leakages is not so dangerous as one single hole of the same area;
- striking hygrothermal effects can be observed even for small local leakages with cross-section 20 x 20 mm and less;
- position of local leakages has significant effect: mean relative humidity of air in the ventilated layer

is generally the highest if the leakage is located in the centre of the distance between inlet and outlet;

- water vapour content of air reaches its peak when the single local leakage is situated near the outlet because in this case the water vapour does not have

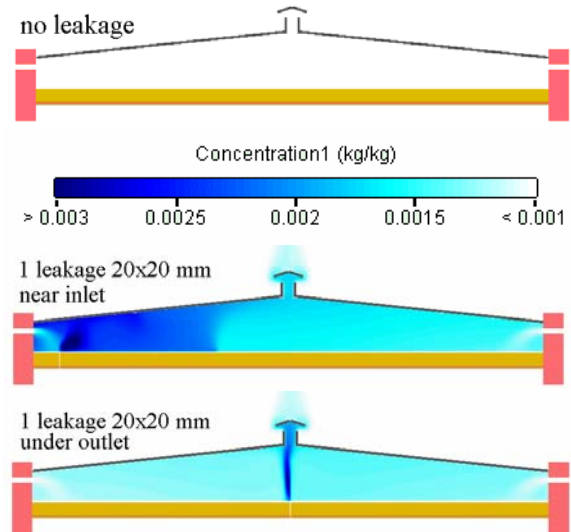

Figure 10 Distribution of water vapour content of air in the ventilated layer of the model roof no. 3

opportunity to disperse more regularly around the ventilated layer;

- better ventilation does not necessarily mean safer roof: higher air flow rate in the ventilated layer usually leads to greater pressure difference between interior and the ventilated layer (with underpressure in the ventilated layer) and this results in higher heat and water vapour transfer through the leakages (or in other words: in higher exfiltration); another reason is the fact that more ventilated air layer is also colder and is able to absorb less water vapour before saturation (compare results for Roof 1 and Roof 3 in Table 2);

however, the worst case is usually a flat roof with very low air flow rate (Roof 2): higher mean air temperature is not sufficient safety factor to avoid massive condensation risk on the whole surface of the upper deck if the roof's internal deck is not perfectly impermeable (Figure 13);

- wind effect is usually positive: water vapour content of air in the ventilated layer is reduced as well as relative humidity of air in spite of lower mean air temperature (the decrease of water vapour content is more influential);

Table 3 Results for Roof 3 subjected to wind

CASE	MEAN VALUES IN THE VENTILATED AIR LAYER			VALUES IN THE CENTRE OF THE OUTLET		
	θ_{am} [°C]	x_{am} [g/kg]	ϕ_{am} [%]	θ_a [°C]	x_a [g/kg]	ϕ_a [%]

Roof 3 : wind 1 m/s						
B	-13,43	1,031	76.1	-13.09	1,031	74.0
C	-12.49	1.424	97.3	-12.42	1.430	97.2
D	-12.48	1.433	97.9	-12.25	1.435	96.2
E	-12.80	1.233	86.4	-12.36	1.446	97.8

Key: see Table 2

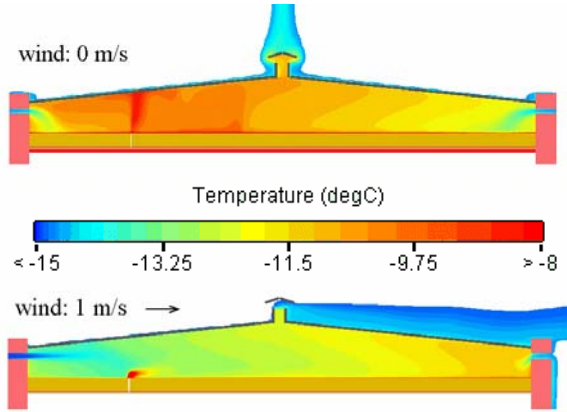

Figure 11 Temperature field in the model roof no. 3 – illustration of wind effect

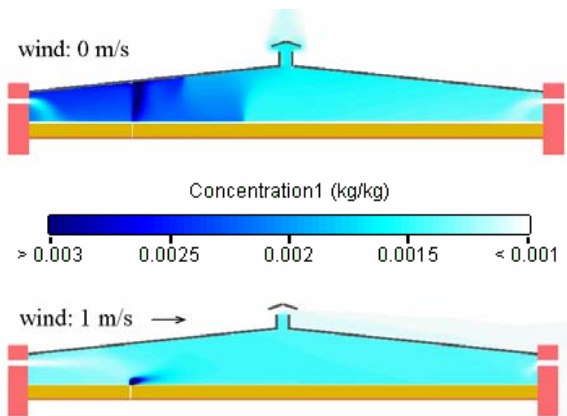

Figure 12 Field of water vapour content of air in the model roof no. 3 – illustration of wind effect

- area of the roof's upper deck subjected to high condensation risk depends on the position of the local leakage: this area is generally larger if the vertical distance between the upper deck and the leakage is low (which usually happens if the leakage is located near the inlet); the surface area threatened by the condensation is also significantly influenced by the circular characteristic of the air flow in the ventilated layer (compare Figure 5 and Figure 13).

CONCLUSION

The air-tightness of the internal deck is a factor of high importance for every ventilated roof. Any leakage can lead to air infiltration or exfiltration and subsequently to significant modifications in the temperature and relative humidity fields. The results of such deformations in the temperature and water vapour distribution include not only increase of the heat loss but in the case of air exfiltration also

substantial increase of the water vapour condensation risk. The final effects can be very severe, especially in specific conditions (e.g. in buildings with moist internal microclimates) as presented here. Higher moisture transport through the permeable construction can easily lead to surprisingly rapid damage beyond all design assumptions. Maximum

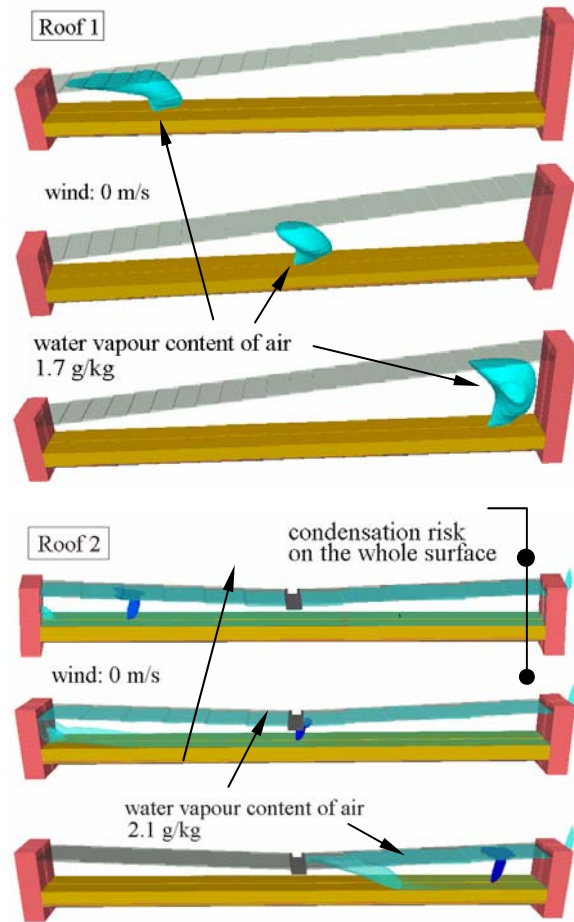

Figure 13 Iso-surfaces indicating high condensation risk on the internal surface of the upper deck

air-tightness of the vapour barrier and other airtight layers is therefore almost obligatory.

Numerical evaluation of permeable and/or leaky ventilated roofs is the task, which cannot be accomplished using common simple procedures from technical standards. One possibility how to solve such problems is to use sophisticated CFD software tools. In spite of some difficulties regarding especially the introduction of water vapour diffusion into CFD calculation, contemporary CFD programs are able to simulate complex transfer processes in ventilated roofs. Their use in the roof design is particularly appropriate in the cases of spatially complicated roofs.

ACKNOWLEDGMENT

This paper was supported by the research program MSM 6840770005.

REFERENCES

- Ciucasu C., Gilles J., Montoya E. and Arquis E. 2005. "Convection phenomena in loose-fill attics," Proceedings of the 7th Symposium Building Physics in the Nordic Countries, Reykjavík: Icelandic Building Research Institute and KTH - Building Technology.
- CSI. 2005. Czech Technical Standard CSN 730540, Thermal Protection of Buildings, Prague: Czech Standards Institute.
- FLOMERICS. 2005. Flovent 6.1, Hampton Court: Flomerics Group PLC.
- Ge H. and Fazio P. 2004. "Experimental evaluation of thermal response and condensation performance of metal curtain walls subjected to air leakage," Journal of Architectural Engineering, 10 (2): 61-68.
- Hagentoft CE. 2001. Introduction to Building Physics, Lund: Studentlitteratur.
- Mortensen LH., Woloszyn M., Hohota R. and Rusaouën G. 2005. "CFD modelling of moisture interactions between air and constructions," Proceedings of the 9th International IBPSA Conference - Building Simulation 2005, Montreal: IBPSA, Vol. II, pp. 801-808.
- Serkitjīs M, Wahlgren P and Hagentoft CE. 2002. "The thermal effects of convection in horizontal insulations," Proceedings of the 6th Symposium Building Physics in the Nordic Countries, Trondheim: Norwegian University of Science and Technology, pp. 103-110.
- Svoboda Z. 2006. "Moisture effects of leakages in building construction: Finite element modelling," Architectural Science Review, 49 (4): 340-348.
- Svoboda Z. 2006. "The use of CFD modelling in the design of ventilated roofs," Proceedings of the 4th National IBPSA Conference – SBTP 2006, Prague: IBPSA CZ, pp. 3-8.
- Wahlgren P. 2002. "Measurements and simulations of convective heat transfer in loose-fill attic insulation," Proceedings of the 6th Symposium Building Physics in the Nordic Countries, Trondheim: Norwegian University of Science and Technology, pp. 95-101.

NOMENCLATURE

- g_d water vapour flow rate [kg/(m²·s)]
- p partial water vapour pressure in air [Pa]
- R_{H_2O} gas constant of water vapour [J/(kg·K)]
- T thermodynamic temperature [K]
- U thermal transmittance [W/(m²·K)]
- v wind velocity [m/s]

- x water vapour content of air [kg/kg]
- Z_{pl} diffusion resistance of the internal deck [m/s],
- β vapour boundary transfer coefficient [kg/(m²·s)]
- φ relative humidity [%]
- θ temperature [°C]
- ρ air density [kg/m³]

subscripts:

- a air in the ventilated air layer
- i internal air
- m mean value
- s external surface of the internal deck